

*Section 9*

**PARTS LIST**

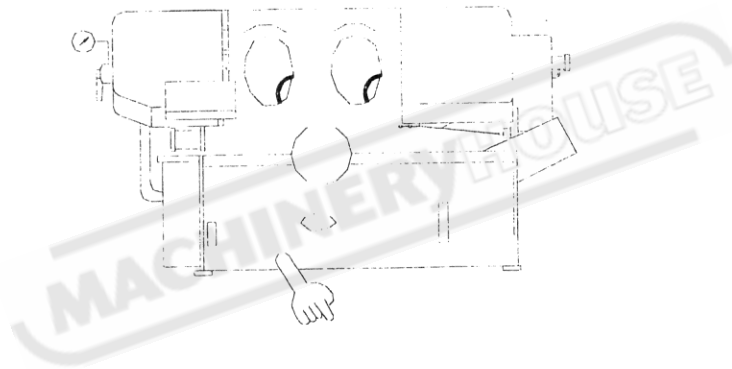

1. SAW BOW

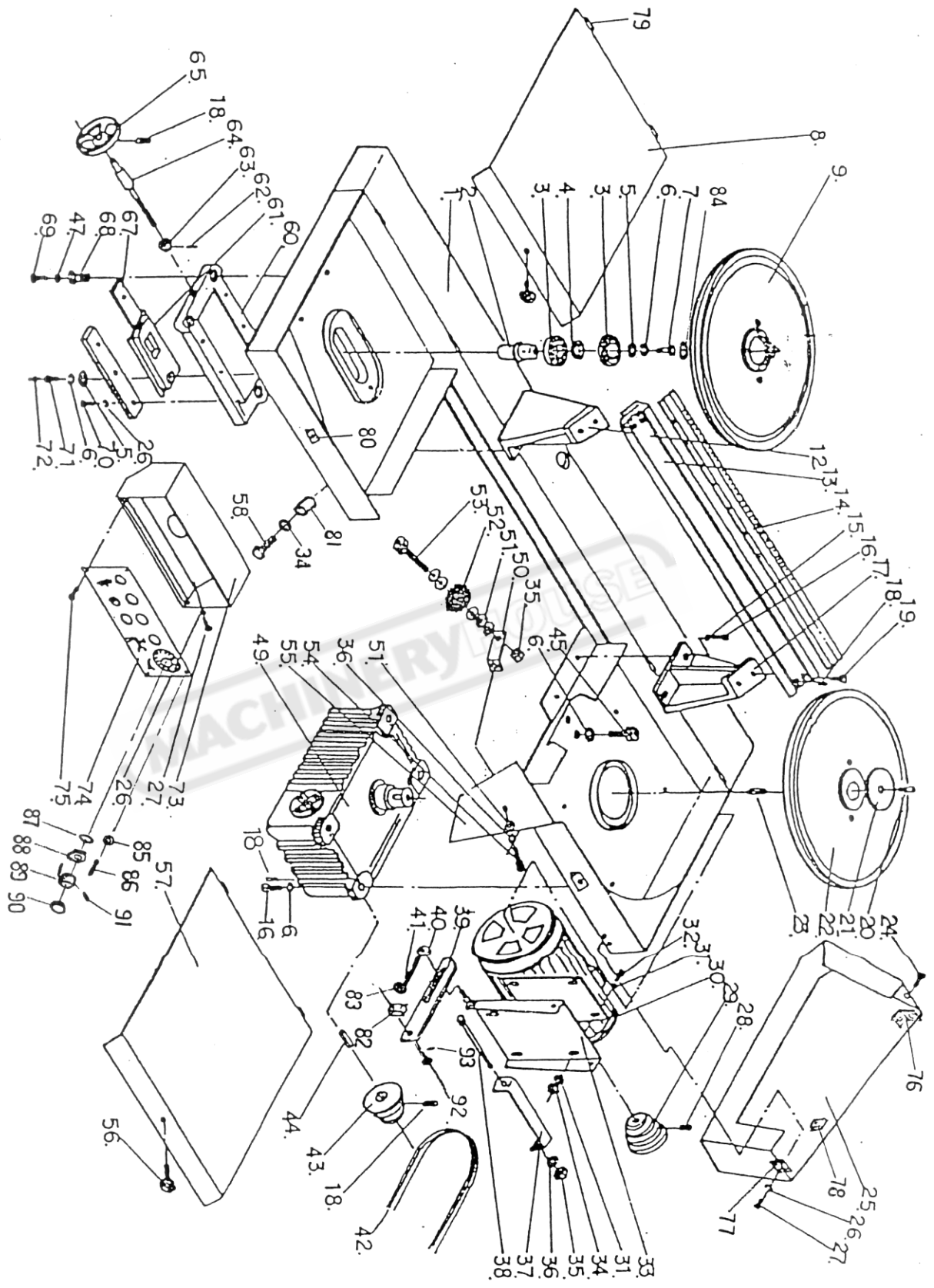

## CHART 1 SAW BOW

NO.	PART NO.	PART NAME	PART NAME IN CHINESE	PART SPEC.	Q'TY
1	SYM-5001	Saw bow	弓鋸頭		1
2	SJY-1114	Idle wheel shaft	上輪軸		1
3	PP-14130	Bearing	軸承	6205Z	2
4	MAE-2025	Bearing washer	上輪軸墊圈		1
5		Washer	平面華司	M12	2
6		Spring washer	彈簧華司	M12	12
7		Bolt	外六角螺絲	M12*20L	1
8	MJA-2014	Wheel cover (left)	上下輪箱蓋		1
9	MJA-2017A	Idle wheel	上輪		1
10				DELETED	
11				DELETED	
12	SYM-5003	Bracket (left)	左鋸臂滑板固定座		1
13	SJY-1105	Dovetail guide	鋸臂滑板		1
14	MJA-2044	Gauge plate (ruler)	銘板	CS-5	1
15		Spring washer	彈簧華司	M12	4
16		Bolt	內六角螺絲	M12*30L	8
17	SYM-5004	Bracket (right)	右鋸臂滑板固定座		1
18		Set screw	止付螺絲	M8*20L	10
19		Screw	內六角螺絲	M10*30L	4
20		Screw	內六角螺絲	5/16*3/4	1
21	MJA-2013	Washer (B)	下輪軸蓋		1
22	SJY-1118	Drive wheel	下輪		1
23		Key	鍵	10*8*20 mm	1
24	PP-53021	Screw	梅花螺絲	M6*12L	1
25	MJA-2008C	Pulley cover	皮帶輪護蓋		1
26		Spring washer	彈簧華司	M6	14
27		Screw	丸頭螺絲	M6*12L	8
28		Set screw	止付螺絲	M8*10L	1
29	SJY-1119	Motor pulley	馬達普利		1
30	PP-31041	Motor	馬達	2HP,4P	1
31		Washer	彈簧華司	M10	8
32		Screw	外六角螺絲	M10*25L	5
33	MJA-2067	Motor mounting plat	馬達底板		1
34		Nut	螺帽	M10	6
35		Nut	螺帽	M8	2
36		Spring washer	彈簧華司	M8	2
37	MJA-2069A	Bracket	馬達調整架		1
38	MJA-2072	Lock screw	馬達架螺絲		1
39	MJA-2068	Adjusting plate	馬達調整板		1
40	SJY-1127	Lock nut	固定螺母		1
41	SJY-1126	Lever	馬達調整固定把手		1
42	PP-56100	V Belt	皮帶	A-39	1
43	MJA-2011C	Transmission pulley	減速機皮帶輪		1
44		Key	鍵	7*7*25 mm	1
45		Bolt	內六角螺絲	M12*40L	6
46				DELETED	

## CHART 1 SAW BOW

NO.	PART NO.	PART NAME	PART NAME IN CHINESE	PART SPEC.	Q'TY
47		Spring washer	彈簧華司	M10	3
48				DEL	
49	PP-16022	Gear box	減速機	70#	1
50	SJY-1136	Bracket	鋼刷固定板		1
51		Washer	平面華司	M8	6
52	PP-58002	Wire brush	鋼刷	90*8 mm #0.3	1
53		Screw	有頭螺絲	M8*30L	1
54		Screw	有頭螺絲	M8*12L	1
55	MAM-2041	Wire brush cover	鋼刷護蓋		1
56	PP-53030	Knob	梅花螺絲	1/4*3/4"	2
57	MJA-2014	Wheel cover (right)	上下輪箱蓋		1
58		Screw	外六角螺絲	M10*25L	1
59				DELETED	
60	SJY-11029	Tension plate	張力調整滑座		1
61	SJY-11029	Adjusting slide	張力調整板		1
62		Spring pin	彈簧銷	φ 3*25L	1
63	MJA-2024	Collar	張力調整固定圈		1
64	SJY-1115	Blade tensioning scr	張力調整螺桿		1
65	SJY-1103	Hand wheel	手輪		1
66				DELETED	
67	SJY-11029	Guide plate	壓條(半)		2
68	SJY-1104	Adjusting bolt	張力調整螺絲	M16*40L	3
69		Screw	外六角螺絲	M10*50L	3
70		Screw	外六角螺絲	M6*20L	6
71	SJY-1150	Nipple	關節油嘴		1
72		Nipple	油嘴	1/16"	1
73	MJA-4005-CE	Control box	控制箱		1
74	MJA-4005C	Control panel	控制面板		1
75		Screw	圓頭螺絲	M4*5L	6
76	KM-2012	Bracket	輪箱蓋固定板		1
77	MAE-2027B	Hinge	鉸鏈		1
78	SJY-1120	Bracket	護蓋固定板		1
79	MJA-1004	Pin	箱蓋栓		4
80	MJA-2054	Bracket	輪蓋固定板		2
81	SJY-1128	Bracket	鋸弓定位塊		1
82	MJA-2070	Adjusting plate	馬達調整塊		1
83	PP-52040	Plastic ball	塑膠球	3/8"	1
84		Snap ring	扣環	R52	2
85		Nut	螺母	M4	1
86	SJY-2108	Pointer rod	指針擋桿		1
87		Washer	平面華司	φ 16	1
88	MAJ-4010	Nut	六角螺帽		1
89	MAJ-4007	Pointer & Bracket	指針及座		1
90	PP-21010	Knob	旋鈕		1
91		Screw	丸頭螺絲	3/16*3/8"	1
92	MJA-2073	Adjusting nut	調整螺母		1

CHART 1 SAW BOW

NO.	PART NO.	PART NAME	PART NAME IN CHINESE	PART SPEC.	Q'TY
93		Pin	開口梢	5/32*1 1/4	1
94					
95					
96					
97					
98					
99					
100					
101					
102					
103					
104					
105					
106					
107					
108					
109					
110					
111					
112					
113					
114					
115					
116					
117					
118					
119					
120					
121					
122					
123					
124					
125					
126					
127					
128					
129					
130					
131					
132					
133					
134					
135					
136					
137					
138					

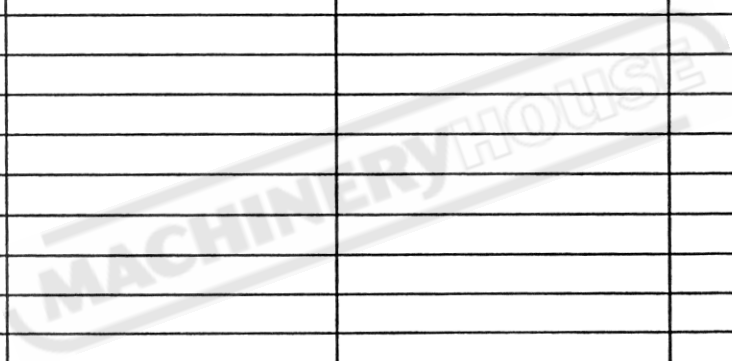

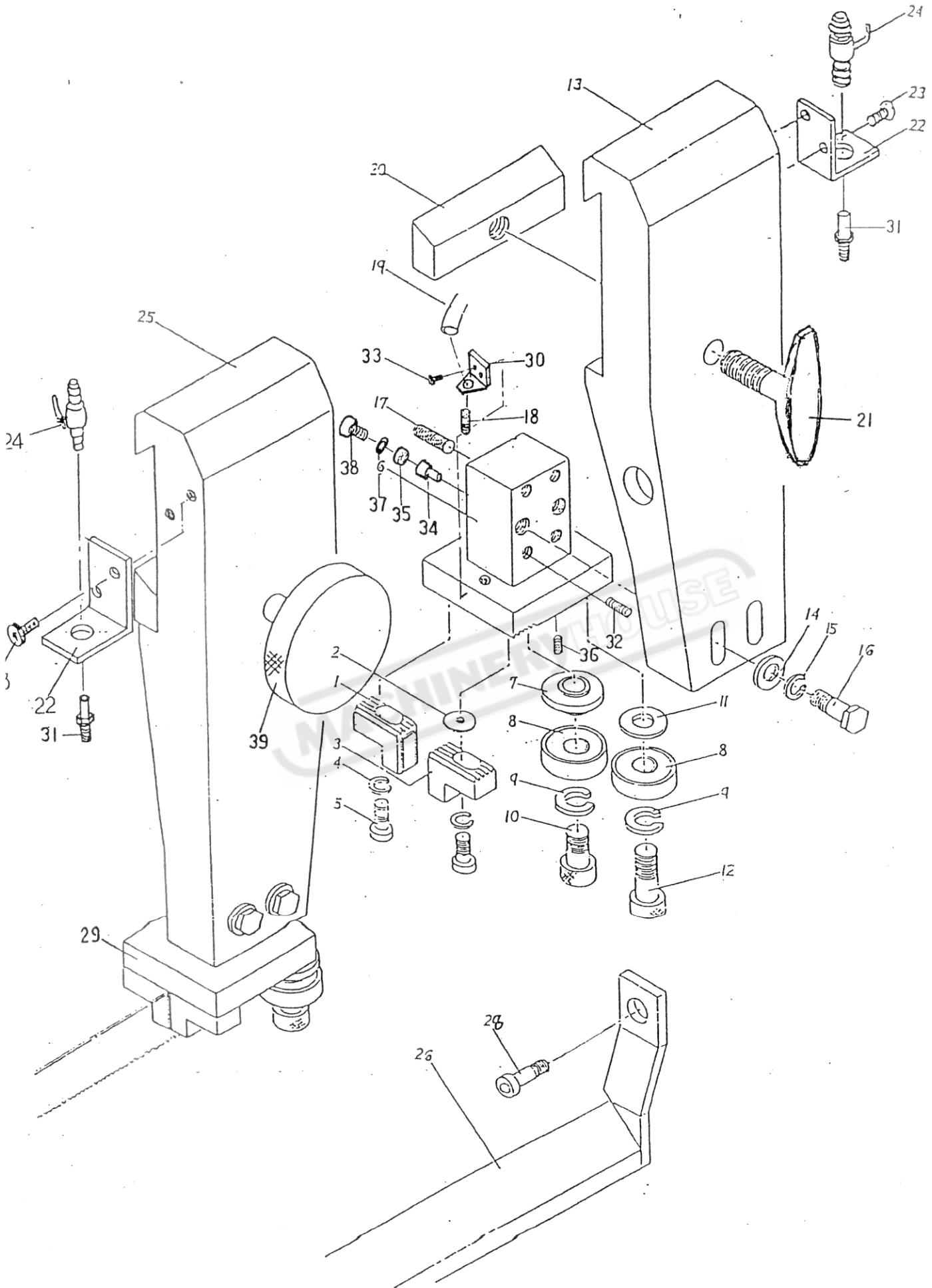

## CHART 2 BLADE GUADE ARMS

NO.	PART NO.	PART NAME	PART NAME IN CHINESE	PART SPEC.	Q'TY
1	MAB-6006	Tungsten carbide blade guide	鋸片固定塊		2
2				DELETED	
3	MAB-6006	Tungsten carbide blade guide	鋸片固定塊		2
4		Spring washer	彈簧華司	M16	4
5		Bolt	內六角螺絲	M6*25L	4
6	SJY-1111	Guide seat	右導輪座		1
7	MAB-6008	Washer	華司		2
8		Bearing	軸承	6202 ZZ	4
9		Spring washer	彈簧華司	M10	4
10		Bolt	內六角螺絲	M10*38L	2
11		Washer	華司	M10	2
12		Bolt	內六角螺絲	M10*25L	2
13	SYM-8006	Guide arm (right)	右鋸臂		1
14		Washer	華司	M8	4
15		Spring washer	彈簧華司	M8	4
16		Bolt	內六角螺絲	M8*32L	4
17		Screw	止付螺絲	M6*12L	4
18	MAB-6014	Fitting	水管接頭固定塊		2
19		Hose	水管	1/4*3000L	2
20	MJA-2032	Clamping block	鋸臂固定塊		2
21	MJA-2031	Knob	鋸臂把手		1
22	MJA-2041	Bracket	水龍頭座板		2
23		Screw	有頭螺絲	M5*10L	4
24	PP-43132	Coolant valve	開關閥	1/8"	2
25	SYM-8005	Guide arm (left)	左鋸臂		1
26	MJA-2038	Blade guard	鋸臂護蓋		1
27				DELETED	
28		Screw	內六角螺絲	M6*10L	1
29	SJY-1110	Guide seat (left)	左導輪座		1
30	SJY-1134	Bracket	水龍頭固定板		2
31	MJA-2043	Fitting	水管接頭		2
32		Set screw	止付螺絲	M8*16L	2
33		Screw	內六角螺絲	M5*10L	4
34	SJY-1112	Bearing shaft	下壓固定軸		2
35	PP-14211	Bearing	軸承	608 VV	2
36		Set screw	止付螺絲	M6*6L	2
37		Washer	平面華司	M4	2
38		Screw	丸頭螺絲	M4*6L	2
39		Bolt	外六角螺絲	1/2-20UNC*2 1/4	1
40					
41					
42					
43					
44					
45					
46					

3. BASE ASSEMBLY AND BED

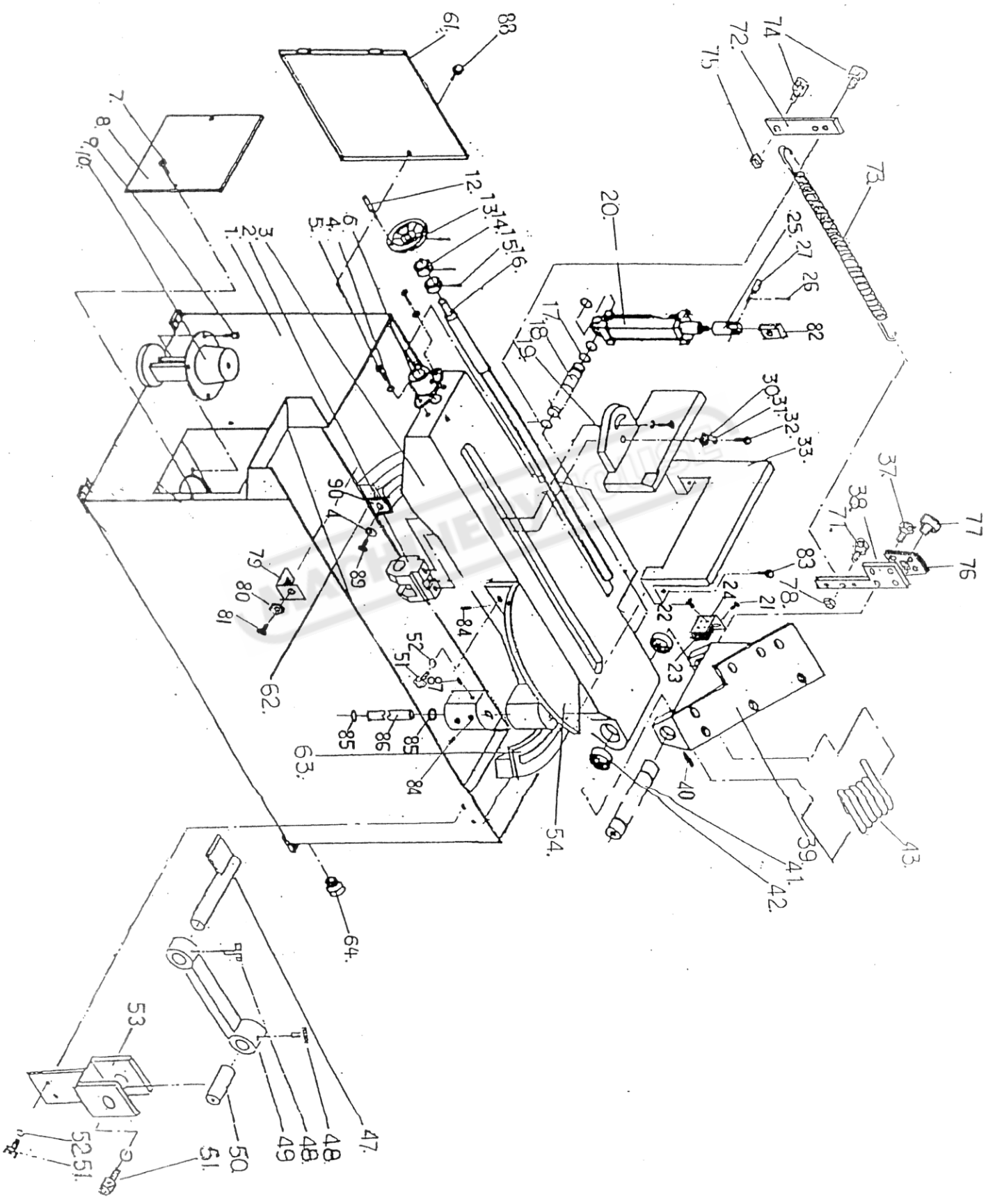



## CHART 3 BASE ASSEMBLY AND BED

NO.	PART NO.	PART NAME	PART NAME IN CHINESE	PART SPEC.	Q'TY
1	MAM-1001-CE	Base	底座		1
2	SJY-1149B	Lead screw nut	導桿螺母		1
3	SYM-6017A	Bed	床面		1
4		Spring washer	彈簧華司	M10	4
5		Bolt	外六角螺絲	M10*25L	2
6	MJA-2012A	Screw sleeve	導螺桿座		1
7		Screw	外六角螺絲	M6*12L	6
8		Pump cover	幫浦護蓋		1
9		Screw	外六角螺絲	M6*20L	4
10	PP-32041	Pump	浸水幫浦	1/8HP,3φ,150L	1
11					
12	PP-52030	Handle	手輪柄	3/8"	1
13	PP-52020	Hand wheel	手輪	6", 20φ	1
14	MJA-1013	Collar	導輪桿固定圈		1
15		Spring pin	彈簧銷	φ 6*30L	1
16	MJA-1014	Vise lead screw	導輪桿		1
17		Snap ring	扣環	A25	1
18	MAM-2032	Cylinder pivot	油壓缸活動軸		1
19	SJY-1151	Movable vise jaw	活動虎鉗		1
20	MJA-1035-CE	Cylinder	油壓缸		1
21		Screw	丸頭螺絲	M6*12L	2
22		Screw	丸頭螺絲	M5*25L	2
23	PP-90010	Limit switch	限動開關	D4MC-5000	1
24	MJA-3102-CE	Switch bracket	限動開關座		1
25				DELETED	
26		Cotter pin	開口銷	5/32*1 1/4"	1
27	MAE-1032	Hinge shaft	油壓缸短插梢		1
28				DELETED	
29	MJA-1024	Depth bar	定寸桿	DELETED	1
30		Washer	平面華司	M12	3
31		Spring washer	彈簧華司	M12	4
32		Bolt	外六角螺絲	M12*48L	4
33	SYM-6002	Fixed vise jaw	固定虎鉗		1
34				DELETED	
35				DELETED	
36				DELETED	
37		Screw	皿頭內六角螺絲	M5*12L	4
38	MAE-5010	Plate	關節座蓋板		1
39	SYM-5002B	Saw bow bracket	關節座		1
40		Set screw	止付螺絲	M6*12L	2
41	SYM-6007	Pivot	關節軸		1
42	PP-13190	Needle bearing	乾式軸承	3015	2
43	MJM-5006B	Spring	回程彈簧		1
44				DELETED	
45				DELETED	
46				DELETED	

## CHART 3 BASE ASSEMBLY AND BED

NO.	PART NO.	PART NAME	PART NAME IN CHINESE	PART SPEC.	Q'TY
47	MBR-9037	Stopper	定寸擋桿		1
48	PP-53009	Lock bolt	梅花螺絲	M10*30L	2
49	MBR-9036	Stopper bracket	定寸滑座		1
50	SYM-6011	Pivot	定寸轉軸		1
51		Screw	外六角螺絲	M8*20L	6
52		Spring washer	彈簧華司	M8	6
53	MAM-1010		定寸座		1
54	MAM-1011		托架		1
55				DELETED	
56				DELETED	
57				DELETED	
58				DELETED	
59				DELETED	
60				DELETED	
61				DELETED	
62	SYM-6008	Turning slide	旋轉軌道 A		1
63	SYM-6009	Turning slide	旋轉軌道 B		1
64		Plug	塞頭	PT 1/2	1
65				DELETED	
66				DELETED	
67				DELETED	
68				DELETED	
69				DELETED	
70				DELETED	
71		Screw	內六角螺絲	M8*20L	1
72	MAE-1033	Bracket	彈簧調整板		1
73	MAE-1039B	Spring	彈簧		1
74	MAM-1034	Bracket	調整板座		1
75		Screw	內六角螺絲	M8*25L	1
76	MLA-1010	Washer	耐磨墊圈		2
77	SYM-5008	Plate	關節墊圈壓板		1
78		Nut	六角螺母	M8	1
79	SYM-6019	Bracket	定位板		2
80		Nut	螺母	M10	2
81		Screw	外六角螺絲	M10*40L	2
82	MJA-1028B	Bracket	油壓缸固定耳		1
83	SYM-6020	Screw	銷螺絲		1
84		Set screw	止付螺絲	M8*16	4
85	PP-13170	Bearing	乾式軸承	2820	2
86	SYM-6013	Rotate shaft	旋轉軸		1
87	SYM-6012	Bracket	旋轉軸固定座		1
88				DELETED	
89		Screw	外六角螺絲	M10*20	2
90	SYM-6014	Fixed nut	固定螺母		2
91					
92					

MH-1016JAM